

Basic features

Application	Cylinder model EUROMECC, all piston diameters Pneumatic cylinder with integrated mounting rail
Basic standard	Dimension tolerances: DIN ISO 2768 m
Principle of operation	BMF mounting bracket
Scope of delivery	Fastening part Mounting bracket
Use	for magnetic sensors BMF 32

Environmental conditions

Ambient temperature	-40...85 °C
----------------------------	-------------

Material

Material	Aluminum Stainless steel
Surface protection	anodized, black

Mechanical data

Sensor attachment	Threaded pin ISO 4026 M4x6-A2 (over pressure plate) offset screwdriver ISO 2936 2.0
Size	Dovetail (Mecman)
Tightening torque	0.8 Nm

Help Views

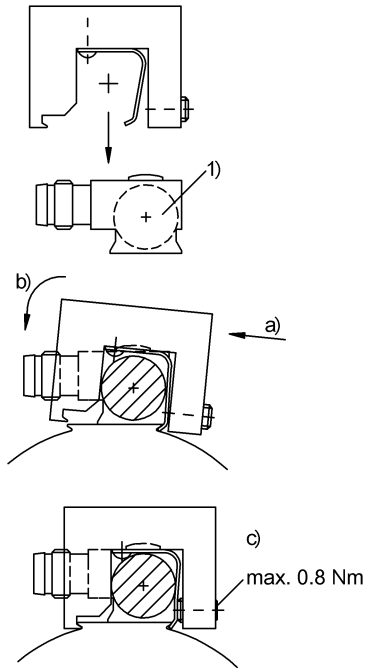

1) Sensor BMF 32